

ROD END BEARINGS – Self-Lubricating

3-Piece Heavy Duty – Male & Female Threads

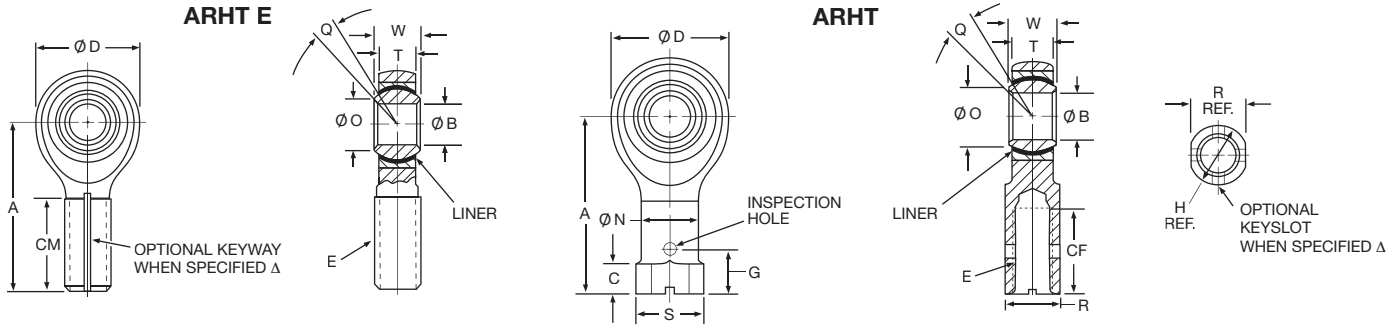

Δ For keyway and keyslot details, refer to the engineering section, pages 68-69.

Part Number	(B) Bore Diameter	(D) Head Diameter	(W) Ball Width	(T) Body Width	(O) Ball Diameter	(A) Flat Diameter	(E) Thread Size	(Q) Mis-alignment	(CM) Thread Length	(CF) Thread Depth	(G) Drill C/L to end	(N) Shank Diameter	(S) Flange Diameter	(C) Flange Thickness	(R) Wrench Flat	No Load Rotational Breakaway Torque	Limit Static Radial Load	Axial Static Proof Load	Weight
	Inch +0.000 -0.005	Inch +0.010 -0.010	Inch +0.000 -0.002	Inch +0.005 -0.005	Inch Ref.	Inch Ref.	Inch +0.010 -0.10	UNF - 3A* UNF - 3B*	Ref.	Inch +0.031 -0.031	Inch Min.	Inch Ref.	Inch +0.010 -0.010	Inch Ref. -0.062	Inch +0.002 -0.010	Inch - lbs.	lbs.	lbs.	lbs. Ref.
ARHT4E ARHT4	.2500	.806	.375	.337	.531	.375	1.562	5/16 - 24	5°	.968						0.5- 6.0	6060	1000	.067 .084
ARHT5E ARHT5	.3125	.900	.437	.327	.593	.401	1.875	3/8 - 24	14°	1.187						1.0-10.0	7290	1100	.095 .102
ARHT6E ARHT6	.3750	1.025	.500	.416	.687	.471	1.938	7/16 - 20	9°	1.187						1.0-10.0	8870	1660	.140 .160
ARHT7E ARHT7	.4375	1.150	.562	.452	.781	.542	2.125	1/2 - 20	10°	1.281						1.0-10.0	9560	1850	.210 .230
ARHT8E ARHT8	.5000	1.337	.625	.515	.875	.612	2.438	5/8 - 18	9°	1.468						1.0-10.0	18560	2040	.330 .340
ARHT10E ARHT10	.6250	1.525	.750	.577	1.062	.752	2.625	3/4 - 16	12°	1.562						1.0-10.0	20610	2430	.480 .490
ARHT12E ARHT12	.7500	1.775	.875	.640	1.250	.892	2.875	7/8 - 14	13°	1.687						1.0-10.0	27640	2810	.730 .740

* UNF-3A = Male Thread. UNF-3B = Female Thread per MIL-S-7742, Rev. D.

Notes:

- † Plating: When specified in materials block, body cadmium plated all surfaces per AMS-QQ-P-416.
- Dimensions: Dimensions apply after plating.
- Temperature: Operating temperature range -65° to 350°F (ADY only).
- Qualifications: Liner is approved to MIL-B-8942 Rev. A (ARHT series only).
- Options:
 1. For left hand threads, add "L" to prefix. (Examples: ARHTL4E or ARHTL4)
 2. For Keyway or keyslot options add suffix "W" to part number.
 3. For "J" form threads per AS8879, add suffix "J" to part number. (Examples: ARHT10EJW or ARHT10JW)

Materials (ARHT)

Designation	Ball	Race	Liner	Body
Basic†	CRES 440C	Stainless	PTFE	C.M. Steel
Part No.	AMS 5630 Rc55-62	Steel, H.T.††	Fabric Bonded to Race I.D.	H.T., Cadmium Plated
No. + CR	CRES 440C AMS 5630 Rc55-62	Stainless Steel, H.T.††	PTFE Fabric Bonded to Race I.D.	CRES 17-4PH AMS 5643 H.T.

† Stainless Steel Series may be ordered to NHBB Part Number as indicated.

†† Part No. designation as shown furnished with CRES 410 race material. To specify CRES 17-4PH race material, add suffix "H" to designation. Examples: ARHT8ECRH or ARHT8CRH.