

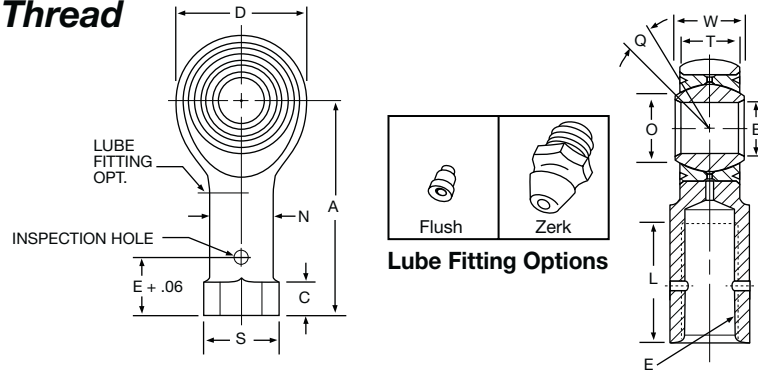

3-Piece Female Thread



Part Number	(B) Bore Diameter	(D) Head Diameter	(W) Ball Width	(T) Body Width	(O) Shoulder Diameter	Ball Diameter	(A) Ball C/L to End	(E) Thread Size	(Q) Misalignment	(L) Thread Depth	(N) Shank Diameter	(S) Flange Diameter	(C) Flange Thickness	Ultimate Static Radial Load*	Weight
	Inch	Inch	Inch	Inch	Inch	Inch	Inch			Inch	Inch	Inch	Inch	lbs.	lbs.
	+ .0000		+ .000	+ .005			+ .06			+ .00	+ .010				Ref.
	-.0005	Max.	-.005	-.005	Ref.	Ref.	-.06	UNF - 3B	Ref.	-.09	-.010	Ref.	Ref.		
AB3	.1900	.781	.437	.337	.301	.531	1.375	5/16 - 24	16°	.750	.437	.500	.180	5170	.06
AB3-101	.1900	.781	.437	.337	.301	.531	1.000	1/4 - 28	16°	.375	.375	.440	.180	5170	.06
AB3-102	.1900	.781	.437	.337	.301	.531	1.375	1/4 - 28	16°	.750	.375	.440	.180	5170	.07
AB3-103	.1900	.875	.500	.337	.318	.593	1.625	5/16 - 24	23°	.750	.500	.560	.180	6840	.11
AB4	.2500	.781	.437	.337	.301	.531	1.375	1/4 - 28	16°	.750	.375	.440	.180	5170	.07
AB4-101	.2500	.781	.437	.337	.301	.531	1.469	5/16 - 24	16°	.750	.437	.500	.180	5170	.08
AB4-102	.2500	.875	.500	.327	.318	.593	1.625	5/16 - 24	24°	.750	.500	.560	.180	6680	.10
AB4-103	.2500	.750	.375	.296	.376	.531	1.312	1/4 - 28	11°	.750	.375	.440	.180	4750	.06
ARB4	.2500	.750	.375	.281	.376	.531	1.312	1/4 - 28	13°	.750	.375	.437	.180	4550	.06
AB5	.3125	.875	.437	.327	.402	.593	1.375	5/16 - 24	14°	.750	.437	.500	.180	6680	.08
ARB5	.3125	.875	.437	.344	.402	.593	1.375	5/16 - 24	12°	.750	.437	.500	.180	6940	.07
AB6	.3750	1.000	.500	.406	.472	.687	1.625	3/8 - 24	10° 30'	.937	.562	.620	.180	9540	.12
ARB6	.3750	1.000	.500	.406	.472	.687	1.625	3/8 - 24	10° 30'	.937	.562	.625	.180	9540	.12
AB7	.4375	1.125	.562	.442	.544	.781	1.812	7/16 - 20	11° 30'	1.062	.625	.680	.180	10430	.18
ARB7	.4375	1.125	.562	.437	.544	.781	1.812	7/16 - 20	12°	1.062	.625	.750	.180	10350	.18
AB8	.5000	1.312	.625	.515	.614	.875	2.125	1/2 - 20	9° 30'	1.125	.750	.870	.180	18620	.28
ARB8	.5000	1.312	.625	.500	.614	.875	2.125	1/2 - 20	10° 30'	1.187	.750	.875	.180	18210	.28
AB10	.6250	1.500	.750	.567	.752	1.062	2.625	5/8 - 18	12° 30'	1.500	.875	.930	.250	20030	.42
ARB10	.6250	1.500	.750	.562	.752	1.062	2.500	5/8 - 18	13°	1.500	.875	.937	.250	19890	.42
AB12	.7500	1.750	.875	.640	.894	1.250	2.875	3/4 - 16	13° 30'	1.750	1.000	1.060	.250	28200	.63
ARB12	.7500	1.750	.875	.687	.894	1.250	2.875	3/4 - 16	11°	1.750	1.000	1.062	.250	29740	.63
ARB14	.8750	2.000	.875	.765	1.062	1.375	3.375	7/8 - 14	6°	1.875	1.125	1.187	.312	43040	.90
ARB16	1.0000	2.750	1.375	1.015	1.275	1.875	4.125	1 - 12	14° 30'	2.125	1.250	1.312	.375	78410	2.00
ARB20	1.2500	2.875	1.500	1.250	1.460	2.093	5.000	1 1/4 - 12	7° 30'	3.125	1.688	1.750	.375	86380	3.10

* Load ratings are for rod ends without lubrication fittings.

NHBB P/N

