

LOADER SLOT BEARINGS

Rod End – 2-Piece Male Thread

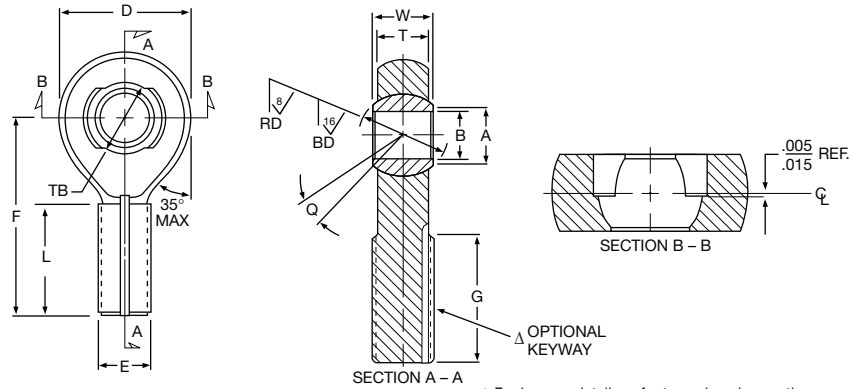

Δ For keyway details, refer to engineering section, page 68.

Part Number	(B) Bore Diameter	(D) Head Diameter	(W) Ball Width	(T) Body Width	(BD) Ball Spherical Diameter	(RD) Rod End Spherical Diameter	(A) Ball Flat Diameter	(Q) Mis-alignment	(TB) Thru Bore	(F) Ball C/L To End	(E) Thread Size	(L) Thread Length	(G) Keyway Flat	Limit Static Radial Load	Ultimate Static Radial Load	Weight
	Inch +.0000 -.0005	Inch +.010 -.010	Inch +.000 -.002	Inch +.010 -.010	Inch +.0000 -.0005	Inch +.0005 -.0000	Inch Ref.	Ref.	Inch +.003 -.003	Inch +.010 -.010	UNJF-3A	Inch +.031 -.031	Inch +.020 -.020	lbs.	lbs.	lbs. Ref.
AMBM3	.1900	.680	.281	.228	.4060	.4070	.293	10°	.360	1.315	1/4-28	.775	.896	2820	4950	.04
AMBM4	.2500	.827	.343	.260	.5000	.5010	.364	10°	.449	1.443	1/4-28	.775	.896	3380	7200	.05
AMBM5	.3125	.984	.375	.291	.5625	.5635	.419	10°	.503	1.948	5/16-24	1.187	1.308	5440 *	11250	.08
AMBM6	.3750	1.131	.406	.322	.6250	.6260	.475	9°	.563	2.030	3/8-24	1.187	1.308	8380 *	15750	.12
AMBM7	.4375	1.294	.437	.353	.7180	.7190	.530	8°	.651	2.250	7/16-20	1.281	1.402	11320 *	19350	.17
AMBM8	.5000	1.459	.500	.400	.8125	.8135	.600	8°	.733	2.544	1/2-20	1.468	1.589	15420 *	25200	.25
AMBM10	.6250	1.763	.625	.510	.9680	.9690	.739	8°	.857	2.832	5/8-18	1.562	1.683	24910 *	40500	.46
AMBM12	.7500	2.140	.750	.603	1.1870	1.1880	.920	8°	1.056	3.193	3/4-16	1.687	1.808	35210	58500	.77
AMBM14	.8750	2.372	.875	.713	1.3120	1.3130	.980	8°	1.138	3.677	7/8-14	2.000	2.121	40500	78300	1.14
AMBM16	1.0000	2.681	1.000	.807	1.5000	1.5010	1.118	9°	1.300	3.968	1-12	2.100	2.221	46580	101250	1.65

*Shank limited.

NHBB Part Numbering

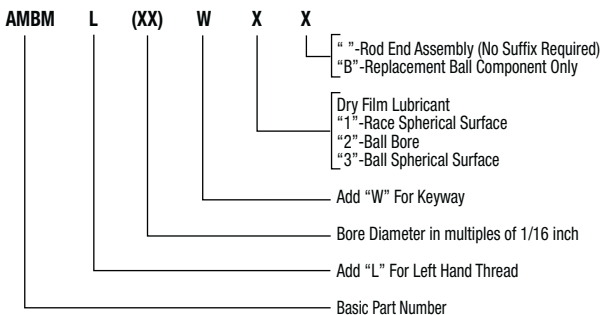

Notes:

- Nitride or Malcomize spherical body ID.
- Balls rotate freely under finger pressure @ 72°F.
- Balls are fully interchangeable. No selective assembly allowed.
- After limit load, slight crazing of the Nitride/Malcomized surface treatment may occur.

Materials

Part No.	Ball	Body
Catalog No.	Stellite® #6, AMS 5387, Rc37 min.	17-4PH AMS 5643 or AMS 5355, Rc34-40

STELLITE® is a registered trademark of DELORO STELLITE COMPANY, INC.