

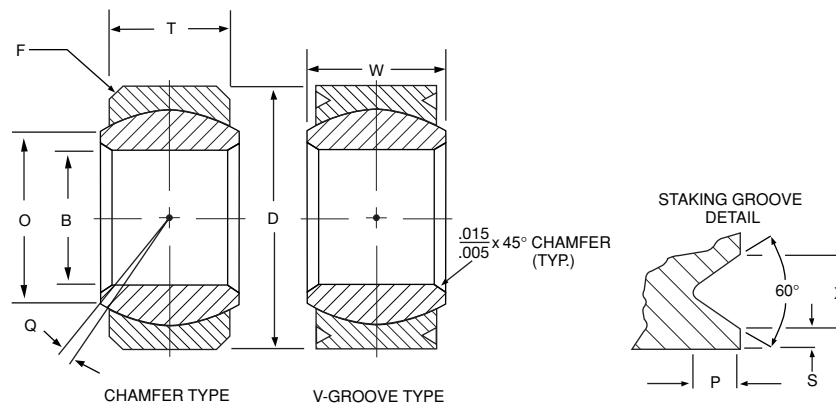

Wide

NHBB P/N

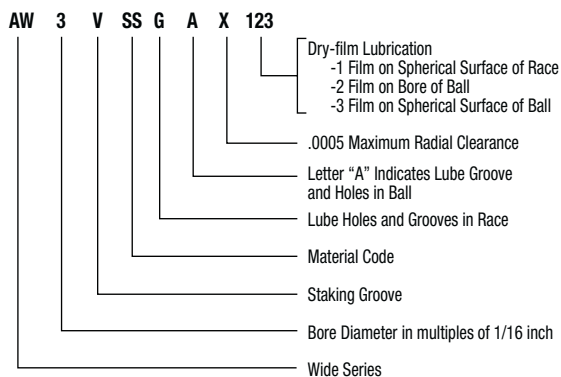

Part Number V-Grooved*	(B)	(D)	(W)	(T)	(O)	Ball Diameter	(F)	(Q)	(P)	(R)	(S)	(X)	Limit Static Radial Load(†)		Weight
	Bore Diameter	Outside Diameter	Ball Width	Race Width	Shoulder Diameter		Race Chamfered x 45°	Mis- alignment	Staking Groove Data			Bronze Race	Steel Race	lbs.	
	Inch +.0000 -.0005	Inch +.0000 -.0005	Inch +.000 -.005	Inch +.010 -.000	Inch Ref.	Inch Ref.	Inch +.000 -.015	Ref.	Inch +.000 -.015	Inch +.000 -.010	Inch +.000 -.010	Inch +.000 -.010	lbs.	lbs.	lbs. Ref.
AW3-5V	.1900	.6250	.437	.322	.301	.531	.025	18°	.030	.015	.020	.045	4060**	4060**	.030
AW3V	.1900	.5000	.359	.281	.249	.437	.025	15°	.030	.015	.020	.045	4060**	4060**	.015
AW4V	.2500	.6250	.437	.322	.301	.531	.025	18°	.030	.015	.020	.045	7040**	7040**	.030
AW5V	.3125	.6875	.437	.312	.401	.593	.025	15° 30'	.030	.015	.020	.045	8360	11010**	.033
AW6V	.3750	.8125	.500	.401	.471	.687	.025	11°	.040	.020	.030	.055	12740	15860**	.053
AW7V	.4375	.9375	.562	.437	.542	.781	.025	12°	.040	.020	.030	.055	15890	21600**	.079
AW8V	.5000	1.0000	.625	.500	.612	.875	.035	10° 30'	.040	.020	.030	.055	20560	28220**	.097
AW9V	.5625	1.1250	.687	.531	.726	1.000	.035	11°	.040	.020	.030	.055	23550	35720**	.133
AW10V	.6250	1.1875	.750	.562	.752	1.062	.035	13°	.040	.020	.030	.055	26660	44110**	.140
AW12V	.7500	1.3750	.875	.625	.892	1.250	.035	14°	.060	.020	.030	.080	35310	63520	.232
AW14V	.8750	1.6250	.875	.750	1.061	1.375	.035	6° 30'	.060	.020	.030	.080	47440	85390	.346
AW15-101V	.9375	1.3750	.450	.350	1.100	1.188	.025	5°	.060	.020	.030	.080	19010	34210	.090
AW16V	1.0000	2.1250	1.375	1.000	1.275	1.875	.035	15°	.060	.020	.030	.080	88120	112980**	.970
AW18V	1.1250	2.2500	1.437	1.067	1.338	1.968	.035	14°	.060	.020	.030	.080	98600	143010**	1.000
AW20V	1.2500	2.3750	1.500	1.125	1.460	2.093	.035	13°	.060	.020	.030	.080	111450	176570**	1.110
AW20-5V	1.2500	2.0000	1.093	.937	1.406	1.781	.035	6°	.060	.020	.030	.080	78100	140570	.564
AW22V	1.3750***	2.5625	1.687	1.218	1.535	2.281	.045	15°	.060	.020	.030	.080	129790	213670**	1.390
AW24V	1.5000***	2.6875	1.687	1.218	1.693	2.390	.045	14°	.060	.020	.030	.080	135990	244780	1.480
AW26V	1.6250***	2.8750	1.750	1.281	1.828	2.531	.045	13°	.060	.020	.030	.080	121580	273570	1.750
AW28V	1.7500***	3.0000***	1.812	1.312	1.964	2.672	.045	13°	.060	.020	.030	.080	131670	296270	1.910
AW30V	1.8750***	3.1250***	1.875	1.343	2.096	2.812	.045	13°	.060	.020	.030	.080	142060	319640	2.120
AW32V	2.0000***	3.2500***	1.937	1.375	2.208	2.937	.045	13°	.060	.020	.030	.080	152140	342310	2.220
AW36V	2.2500***	3.6250***	2.000	1.406	2.442	3.156	.045	12° 30'	.060	.020	.030	.080	167390	376640	2.780
AW40V	2.5000***	3.9375***	2.062	1.437	2.750	3.437	.045	12°	.060	.020	.030	.080	186560	419760	3.280
AW44V	2.7500***	4.1250***	2.187	1.500	2.968	3.687	.045	12°	.060	.020	.030	.080	209420	471200	3.550
AW48V	3.0000***	4.3750***	2.312	1.562	3.187	3.937	.045	12° 30'	.060	.020	.030	.080	233380	525120	4.000

* For chamfered version, delete 'V' from part number.
 ** Based on pin limitation.
 *** Tolerance: +.0000-.0008.
 † Loads based on parts with no lubrication grooves.